

# An inherently synchronized Yb fiber laser extension unit for broadly tunable, femtosecond pulse Ti-sapphire lasers for CARS microscopy

A. Csáti<sup>1</sup>, P. Antal<sup>1</sup>, R. Szipócs<sup>1,2,\*</sup>

<sup>1</sup> Research Institute for Solid State Physics and Optics, P.O. Box 49, H-1525 Budapest, Hungary

<sup>2</sup> R&D Ultrafast Lasers Ltd, P.O. Box 622, H-1539 Budapest, Hungary

\* r.szipocs@szipocs.com

**Abstract:** An inherently synchronized Yb-fiber laser based extension unit for femtosecond pulse, broadly tunable Ti-sapphire lasers is introduced, which is well suited for coherent anti-Stokes Raman scattering microscopy.

**OCIS codes:** (140.7090) Ultrafast lasers; (180.4315) Nonlinear microscopy

## 1. Introduction

For biomedical imaging applications, the real advantage of nonlinear microscopy stems from its ability to image deeply with minimum perturbation in the biological sample. It has the potential for high spatial resolution, *in vivo* 3D tomography of the human skin at depths down to 200-500  $\mu\text{m}$ , since there is no out-of-focus photo-stress and bleaching. Its application for melanoma detection diagnostics, cosmetic research, skin aging measurements and drug monitoring has already been demonstrated [1]. Optical disease diagnosis can be enhanced in sensitivity by the application of exogenous labels to obtain molecularly specific information from the tissue, but these are typically toxic. Intrinsic fluorophores, such as elastin, melanin, flavines and reduced nicotinamide adenine dinucleotide (NADH), are naturally part of the skin and can be used for imaging. The excitation of these biomarkers with different laser wavelengths reveals the morphologic structure of the skin and chemical fingerprinting. Additionally, second harmonic generation (SHG) can be induced to detect the collagen network [2]. Since the early 1990-es, broadly tunable, femtosecond pulse Ti:sapphire lasers [3] comprising all solid-state pump lasers are used for single wavelength excitation of the artificial or natural fluorophores in nonlinear microscopy.

Coherent Raman scattering (CRS) methods such as coherent anti-Stokes Raman scattering (CARS) [4] and stimulated Raman scattering (SRS) [5] allow for label-free imaging of tissue with chemical contrast and high spatial and temporal resolution. In CRS, laser beams at two frequencies, called the pump,  $\omega_p$ , and Stokes,  $\omega_s$ , frequencies, are used to illuminate the sample. When the difference frequency between the two beams is tuned to match an intrinsic molecular vibrational frequency in the sample,  $\omega_{\text{vib}}$ , several nonlinear interactions occur. New light is generated at the anti-Stokes frequency,  $\omega_{\text{as}} = 2\omega_p - \omega_s$ , by the CARS process, and some intensity is transferred from the pump to the Stokes beam by the SRS process. Both processes offer chemical selectivity, high spatial resolution, and video-rate imaging speeds *in vivo* in living animals and humans.

Recently, a miniaturized coherent Raman imaging system based on a compact scanning fiber endoscope (SFE) has been reported [6], which is an important step toward translating coherent Raman imaging methods into clinical practice. For the CRS measurements, a passively mode-locked Nd:YVO<sub>4</sub> laser delivering 7 ps pulses at a repetition rate of 80 MHz (being the Stokes beam at 1064 nm), and a synchronously pumped optical parametric oscillator generating a tunable pump beam near 800 nm were used. Both lasers had a typical average power of ~130 mW, which power level has the risk of thermal damage of the biological sample [7]. The relatively high power level required can be explained by the relatively long (~7 ps) pulses used for distortion free fiber delivery and for the CRS process as well. The thermal load of the biological sample could be considerably reduced by using optical pulses of higher peak intensity (i.e., shorter pulses, or higher energy pulses at lower repetition rate [8]), however, for a SFE system it would require hollow core photonic bandgap fibers with tailorable dispersion [9].

For single wavelength nonlinear microscopy, such as multi-photon absorption fluorescence (2P, 3P), SHG and fluorescence lifetime imaging (FLIM), broadly tunable, femtosecond pulse Ti-sapphire lasers are used typically. In this work, we present a simple wavelength extension unit for these tunable lasers comprising a two stage Yb-fiber amplifier unit, which allows CRS measurements practically on the same microscope and lasers setup that is used for single wavelength 3D microscopic imaging.

## 2. Experimental setup

The experimental setup is shown in Fig. 1. A broadly tunable, femtosecond pulse Ti-sapphire laser (*FemtoRose 100TUN NoTouch*, product of R&D Ultrafast Lasers Ltd [10]) generates nearly transform limited,  $\tau_{\text{FWHM}} \sim 190$  fs pulses of for our measurements. The laser is pumped by a 5.5 W, 532 nm solid state laser (*Finesse 6*, product of Laser Quantum). A Faraday isolator (FI) placed in the beam path assures that there is no back reflection to the laser oscillator from the different optical element, such as the optical fiber ends. An achromatic beam-splitter (BS) divides the laser power into two parts: the reflected beam is focused into a small core area photonic crystal fiber (NL-1.4-775, product of NKT Photonics) by a high NA, aspheric focusing lens, which provides the seed pulses for the two-stage Yb-amplifier unit (*FemtoFiber*, product of R&D Ultrafast Lasers Ltd. [10]) operating at around 1030 nm. The transmitted beam, which plays the role of a tunable pump beam for CRS measurements, directly goes into nonlinear microscope through a precision delay stage, which assures the zero delay difference between the tunable pump and amplified, compressed Stokes pulses, the latter one is being generated by the two-stage Yb-amplifier unit. The pump and Stokes pulses are inherently synchronized, since the  $\sim 1030$  nm seed pulse of the amplifier is generated by the Ti:sapphire laser by efficient nonlinear wavelength conversion in a 109 mm long photonic crystal fiber (PCF).

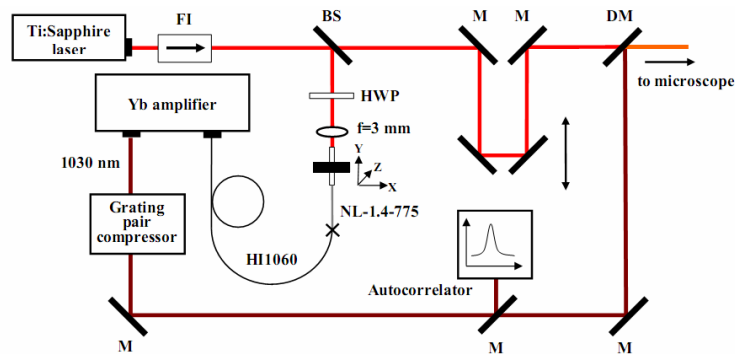

Fig. 1 Setup of the CARS extension unit

## 3. Results

In Fig. 2, the spectral intensity vs. wavelength functions, which were measured directly after the PCF, are plotted for different pump wavelengths at coupled power levels of  $\sim 100$  mW. For seeding the *FemtoFiber* Yb-fiber amplifier, we typically use the chirped optical pulses of an all-fiber, all-normal dispersion ytterbium ring oscillator [11] delivering an average output power of 2-5 mW. Now, we use that portion of the optical spectra depicted in Fig. 2, which are within the gain bandwidth ( $\sim 1020$ -1080 nm) of the Yb-doped optical fiber amplifier. Within this bandwidth, the average power is similar to that of our all-fiber, all-normal dispersion ytterbium ring oscillator [11].

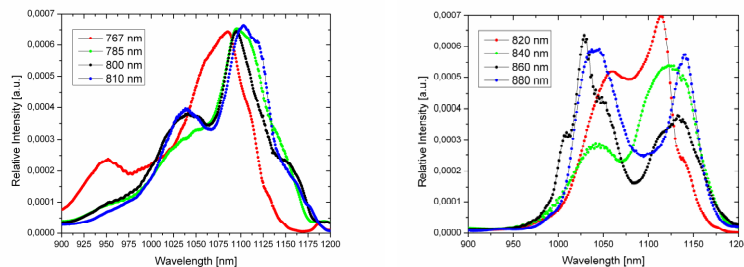

Fig. 2 Measured spectral intensity distribution vs. wavelength functions at different pump wavelengths at coupled power level of  $\sim 100$  mW

After the two-stage Yb-amplifier, we obtain optical pulses with central wavelength of  $\sim 1030$  nm and a FWHM bandwidth of 11 nm, as shown in Fig. 3. In the inset, the measured second-order autocorrelation trace is shown, which is measured after a transmission grating pair compressor (1200 lpmm @ 1032 nm, Wasatch Photonics) at an optimum grating distance of 19 mm, resulting in a nearly transform limited pulse duration of  $\sim 276$  fs. The pump and the Stokes beams are combined by a dichroic beamsplitter (DM), and then transmitted to the nonlinear microscope (Axio Examiner LSM 7 MP, product of Carl Zeiss). Both the pump and the Stokes laser provide nearly transform limited optical pulses, hence we expect a relatively strong anti-Stokes signal in our nonlinear microscope.

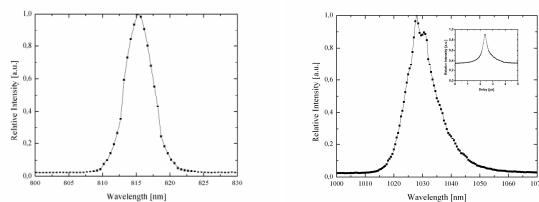

Fig. 3 Measured typical optical spectrum of the tunable Ti-sapphire laser (left) and the two-stage Yb-amplifier (right). In the inset, the measured second-order autocorrelation trace of the Yb-amplifier (after compression) is shown.

The dual wavelength, inherently synchronized laser system has been tested for label-free, coherent anti-Stokes Raman scattering (CARS) imaging in the Axio Examiner LSM 7 MP microscope. Different samples including mouse dorsal skin, muscle tissues and carbon nanotubes were used for testing our novel dual wavelength laser setup. In Fig. 4, we show two images recorded for zero and non-zero delay difference between the pump and the Stokes pulses recorded at an average power level below  $\sim 15$  mW for a carbon nanotube layer sample deposited on an optical glass substrate. According to Raman spectroscopy measurements, the sample has a strong vibration resonance at  $\omega_{\text{vibr}} = 2577$   $\text{cm}^{-1}$ . For the CARS measurements, the pump laser had to be tuned to 814 nm ( $12285$   $\text{cm}^{-1}$ ) in order to satisfy the  $\omega_{\text{vibr}} = \omega_p - \omega_s$  condition. Since the Stokes beam is centered at 1030 nm ( $9708$   $\text{cm}^{-1}$ ), the anti-Stokes signal should be detected on the “red” channel of our nonlinear microscope at the wavelength of 673 nm. For the CARS measurements, the original dichroic beamsplitter and the laser blocking filter in the microscope has been replaced by new ones having a longer cut off wavelength of 760 nm.

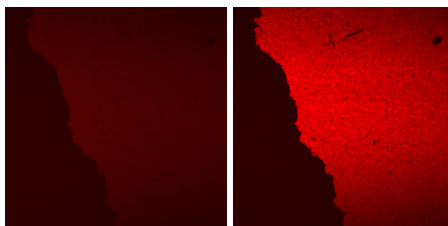

Fig. 4 The 2P autofluorescence (left) and the CARS signal (right) detected on the “red” channel of the nonlinear microscope for non-zero (left) and zero (right) delay difference between the pump and the Stokes pulses

Based on our measurements, we are convinced that the novel, simple, cost efficient, inherently synchronized Yb-fiber laser based extension unit reported here is well suited for upgrading most of the existing single wavelength nonlinear microscope setups for dual wavelength, label-free, coherent anti-Stokes Raman scattering imaging.

#### 4. References

- [1] K. König, “Clinical multiphoton tomography”, *J Biophotonics* **1**, 13-23 (2008).
- [2] H. Breunig, H. Studier, K. König, “Multiphoton excitation characteristics of cellular fluorophores of human skin in vivo”, *Opt. Express* **18**, 7857-7871 (2010).
- [3] E.J. Mayer, J. Möbius, A. Euteneuer, W. Rühle, R. Szipöcs, “Ultrabroadband chirped mirrors for femtosecond lasers” *Optics Letters* **22**, 528-530 (1997).
- [4] C. L. Evans and X. S. Xie, “Coherent Anti-Stokes Raman Scattering Microscopy: Chemical Imaging for Biology and Medicine”, *Annu. Rev. Anal. Chem.* **1**, 883-909 (2008).
- [5] B. G. Saar, C. W. Freudiger, J. Reichman, C. M. Stanley, G. R. Holtom, and X. S. Xie, “Video-Rate Molecular Imaging in Vivo with Stimulated Raman Scattering”, *Science* **330**, 1368-1370 (2010).
- [6] B. Saar, R. Johnston, Ch. Freudiger, X. S. Xie, E. J. Seibel, “Coherent Raman scanning fiber endoscopy”, *Opt. Lett.* **36**, 2396-2398 (2011).
- [7] B. R. Masters, P. T. C. So, C. Buehler, N. Barry, J. D. Sutin, W. W. Mantulin, E. Gratton, “Mitigating thermal mechanical damage potential during two-photon dermal imaging,” *J. Biomed. Opt.* **9**, 1265-1270 (2004).
- [8] P. Gy. Antal, R. Szipöcs, “Tunable, low-repetition-rate, cost-efficient femtosecond Ti:sapphire laser for nonlinear microscopy”, submitted to *Appl. Phys. B* (2011).
- [9] Z. Várallyay, K. Saitoh, A. Szabó, R. Szipöcs, “Photonic bandgap fibers with resonant structures for tailoring the dispersion”, *Opt. Exp.* **17**, 11869-11883 (2009).
- [10] [www.fslasers.com/products/](http://www.fslasers.com/products/)
- [11] J. Fekete, A. Cserteg, R. Szipöcs, “All-fiber, all-normal dispersion ytterbium ring oscillator”, *Laser Physics Letters* **6**, 49-53 (2009).